

AE448
Weld Mount Receptacle
D38999/48

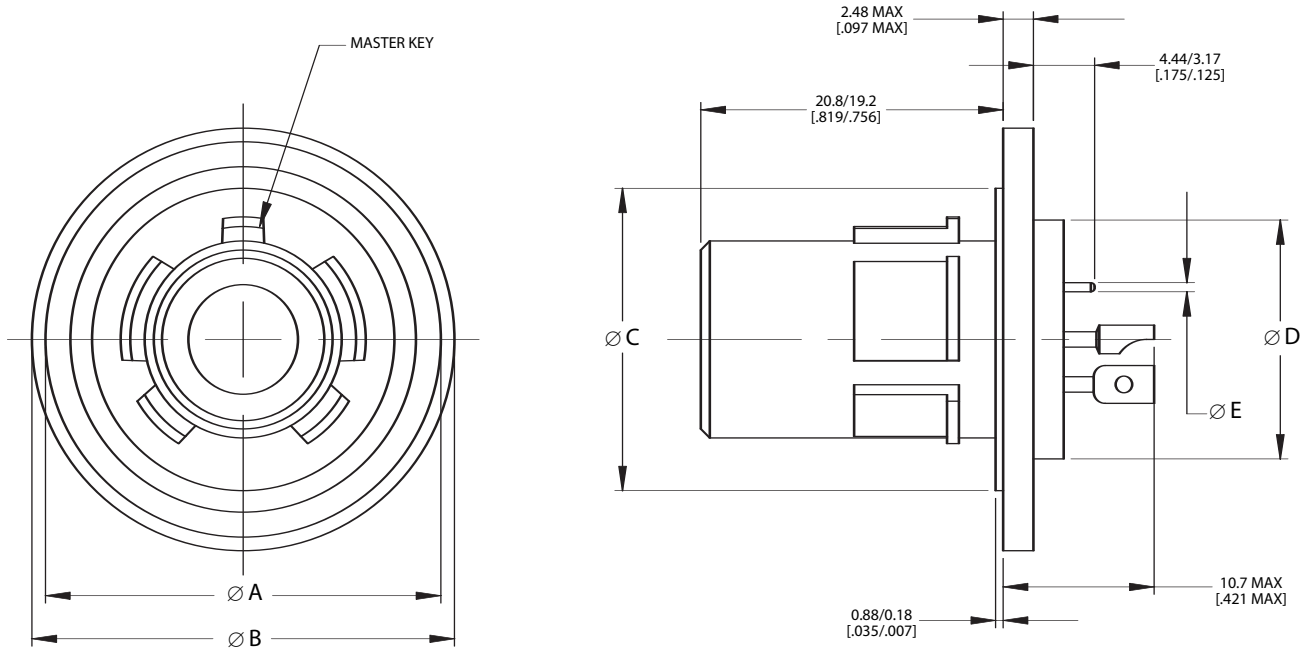

MIL-DTL-38999 S IV



Contact Size	Ø E	
	mm	inch
22D	0.28	.011
	0.38	.015
20	0.60	.024
	0.70	.028
16	1.56	.061
	1.61	.063
12	2.36	.093
	2.41	.095



Shell Size	Shell Size Code	Ø A		Ø B		Ø C		Ø D	
		±0.15	±.006	±0.15	±.006	±0.19	±.007	Maximum	
		mm	inch	mm	inch	mm	inch	mm	inch
11	B	26.15	1.030	27.95	1.100	19.96	.786	15.88	.625
13	C	29.35	1.156	31.15	1.226	23.16	.912	19.05	.750
15	D	32.55	1.281	34.35	1.352	26.33	1.037	23.01	.906
17	E	34.75	1.368	36.55	1.439	29.53	1.163	25.81	1.016
19	F	38.45	1.514	40.25	1.585	32.68	1.287	28.98	1.141
21	G	42.05	1.656	43.85	1.726	35.86	1.412	32.16	1.266
23	H	46.25	1.821	48.05	1.892	39.03	1.537	34.93	1.375
25	J	48.45	1.907	50.25	1.978	42.21	1.662	37.69	1.484